

SA1500 GNSS Antenna

GNSS Antenna
for Reference Station



SA1500 TECHNICAL FEATURES

2D CHOKE RING ANTENNA

The unique 2D choke ring design of SA1500 ensures an excellent multipath reduction performance across all GNSS frequency bands including L-Band. It is ideal for applications of CORS stations, bridge and building deformation monitoring or geological monitoring due to its submillimeter phase center stability.

TRACKING EVERYWHERE

The strong ability to receive low elevation signals with high gain and wide beam width makes SA1500 an excellent choice for tracking visible satellites and provide stable and precision GNSS data under complex environments, such as obstructed environment of tree lines or construction.

STRONG ANTI-INTERFERENCE PERFORMANCE

The antenna LNA features an excellent out-of-band rejection performance, which can suppress the EMI, providing the stability and reliability of GNSS signals. Also it effectively avoids disconnection dangerous when receivers are being interfered by wireless communication systems, for example power grid, communication base station or radio modem applications.

RUGGED

The SA1500 cover is made of Glass Fiber Reinforced Polymer(GFRP) material and is structurally strong and reliable. The IP67 ruggedized cover is also designed to protect the inside antenna from dust and water.

PERFORMANCE

Satellite Signal Tracked	GPS: L1, L2, L5
	GLONASS: L1, L2, L3
	BEIDOU: B1, B2, B3
	GALILEO: E1, E2, E5a, E5b, E6
	QZSS: L1, L2, L5, L6
	IRNSS: L5
	SBAS: L1, L5
L-BAND	
Type	2D Choke Ring Antenna
Phase Center Stability	± 1mm
Nominal Impedance	50Ω
Polarization	RHCP
Axial Ratio	≤2dB
Peak Gain	7dB
LNA Gain	50dB (typical)
Noise Figure	≤2dB
Output/Input VSWR	≤2.0
Operation Voltage	+3.3VDC to +12VDC
Operation Current	60mA (maximum)
Group Delay Ripple	≤5ns

MECHANICAL

Dimensions	Ø322mm x 261mm
Connector	TNC female
Mounting	BSW 5/8"-11 screw, depth ≥22mm
Weight	5.6kg

ENVIRONMENTAL

Operating Temperature	-55°C to 85°C (-67°F to 185°F)
Storage Temperature	-55°C to 85°C (-67°F to 185°F)
Humidity	100% non condensing
Waterproof/Dustproof	IP67

CALIBRATION

NGS	Yes
IGS	Yes

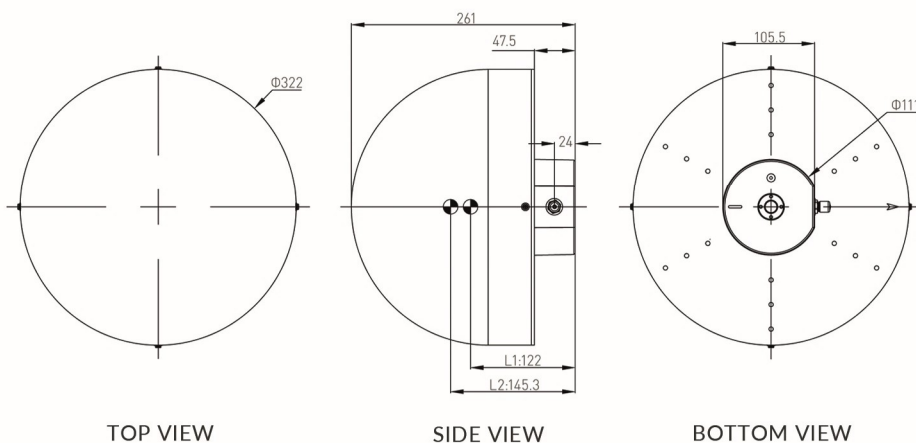

Illustrations, descriptions and technical specifications are not binding and may change

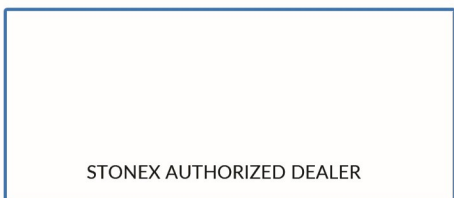

STONEX®
Part of UniStrong

Viale dell'Industria 53 - 20037 Paderno Dugnano (MI) - Italy
Phone +39 02 78619201
www.stonex.it | info@stonex.it